

ASSEMBLY AND INSTALLATION INSTRUCTIONS CONTINUED

RACK ASSEMBLY

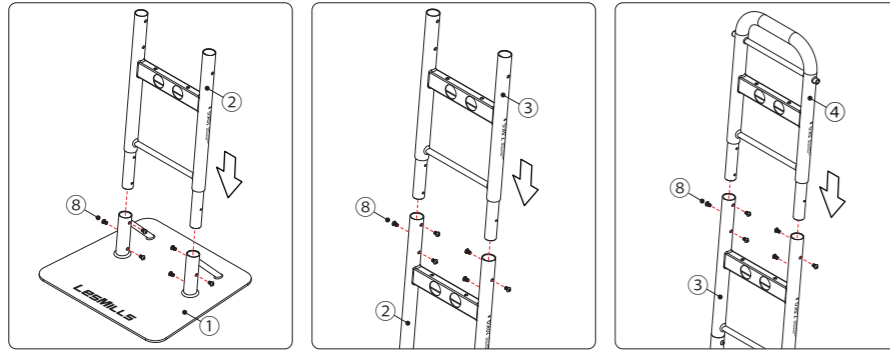

- STEP 1** Insert the Lower frame (2) into the Base (1). Ensuring the frame is correctly orientated as per the illustration (with the two large holes facing towards the logo on the Base). Fasten with six M6 x 10 screws (8) using the M6 Allen key (13).
- STEP 2** Insert the Middle frame (3) into the Lower frame (2). Ensuring the frame is correctly orientated as per the illustration (with the two large holes facing towards the logo on the Base). Fasten with six M6 x 10 screws (8).
- STEP 3** Insert the Upper frame (4) into the Middle frame (3). Ensuring the frame is correctly orientated as per the illustration (with the two large holes facing towards the logo on the Base). Fasten with six M6 x 10 screws (8).

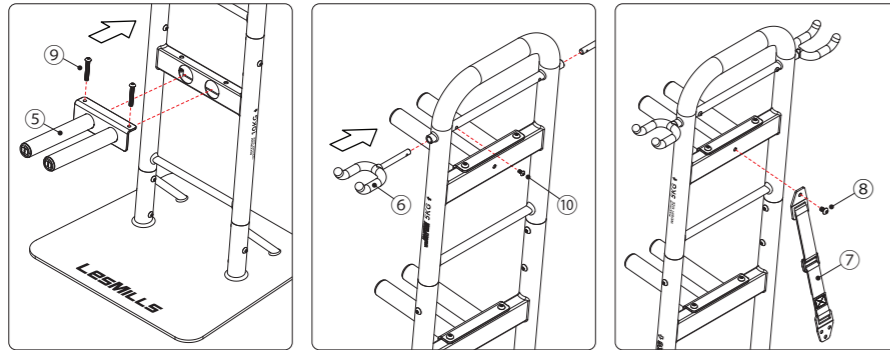

- STEP 4** Attach Weight hanger (5) to the lowest position and fasten with two M6 x 40mm screws (9). Repeat this step for the other two Weight hangers.
- STEP 5** Attach the two Side hooks (6) to each indicated location and fasten with two M4 x 8mm screws (10).
- STEP 6** Attach the Anti-tip Strap (7) to the rear of the Upper frame (4), behind the Weight hanger with one M6 x 10mm screws (8).
- STEP 7** Check all fasteners are fully tightened and there is no movement between the parts.

⚠ WARNING: FAILURE TO INSTALL THE ANTI-TIP STRAP COULD RESULT IN SERIOUS INJURY OR DEATH.

Please now install the VERTICAL STORAGE rack to the wall as per the assembly instructions under **ANTI-TIP STRAP INSTALLATION TO THE WALL.**

ANTI-TIP STRAP INSTALLATION TO THE WALL

The VERTICAL STORAGE rack has been designed to be placed against a wall, on a hard level floor with the Anti-tip straps firmly anchored into a plasterboard wall with a wooden stud, or a concrete/brick wall. Please ensure that no equipment is placed on the VERTICAL STORAGE rack during assembly.

The supplied wall plugs are suitable for concrete and brick walls. For other wall types, special wall plugs must be used. Wall structures vary. Please consult a construction professional to confirm whether your wall structure is appropriate for installation of this VERTICAL STORAGE rack.

The Anti-tip strap (7) should already be attached to the VERTICAL STORAGE rack. If not, please follow Step 6 under the rack assembly instructions.

FOR PLASTERBOARD / DRYWALL (for walls with existing studs)

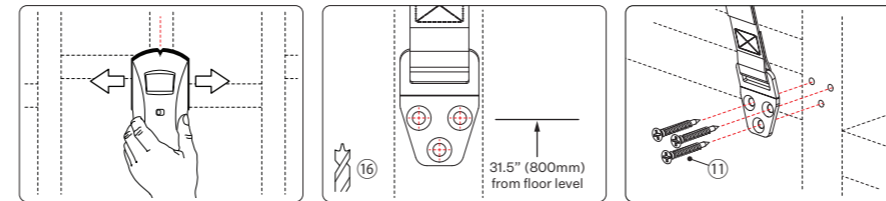

- STEP 1** Use a stud finder to locate and mark the location of the stud closest to the position where the VERTICAL STORAGE rack will be placed.
- STEP 2** The Anti-tip wall bracket should be installed 31.5" (800mm) above the floor height. Mark and drill 7/64" (3mm) pilot holes into the stud at each marked location.
- STEP 3** Use three 45mm long screws (11) and fasten the Anti-tip wall brackets firmly into the wall.
- STEP 4** Place the VERTICAL STORAGE rack up against the wall and then tighten the adjustable strap so it is taut between the wall and the rack. Ensure that all four feet on the Base plate remain on the ground.

FOR CONCRETE / BRICK WALL

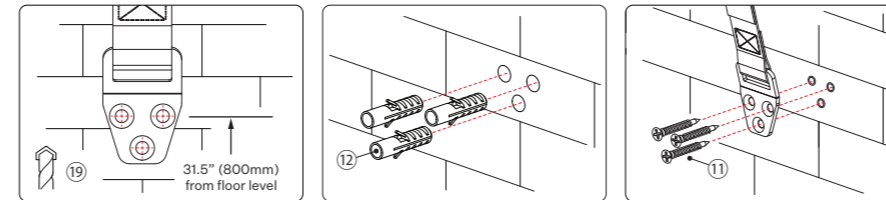

- STEP 1** The Anti-tip wall bracket should be installed 31.5" (800mm) above the floor height. Mark and drill 7/32" (5.5mm) holes at each marked location.
- STEP 2** Install the supplied wall expansion anchors (12) into the 7/32" (5.5mm) holes until they sit flush with the wall.
- STEP 3** Use three 30mm long screws (11) and fasten the Anti-tip wall brackets firmly into the wall.
- STEP 4** Place the VERTICAL STORAGE rack up against the wall and then tighten the adjustable straps so they are taut between the wall and the rack. Ensure that all four feet on the base plate remain on the ground.

Ensure the VERTICAL STORAGE rack is securely anchored, without any movement before use. We recommend testing the product by initially placing one weight onto the VERTICAL STORAGE rack at a time.

For warranty information visit: <https://www.lesmills.com/merchandise/equipment/warranty/>

LES MILLS SMARTBAR

VERTICAL STORAGE RACK

WITH REQUIRED ANTI-TIP STRAP FOR SECURELY ANCHORING TO A WALL

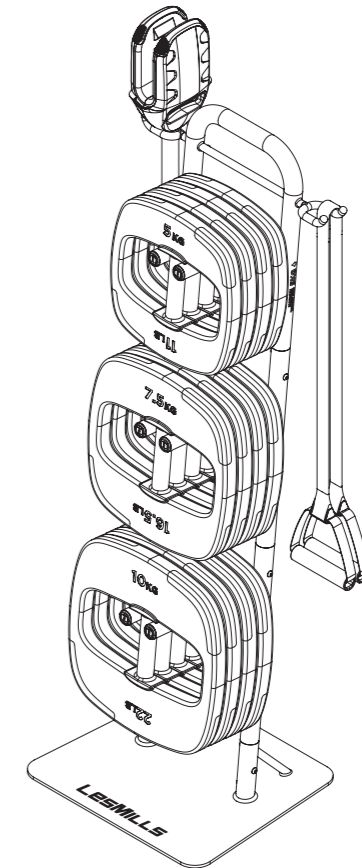

ASSEMBLY & USER INSTRUCTIONS

PLEASE KEEP FOR FUTURE REFERENCE

D2CRCKFS-C

SMARTBAR™ VERTICAL STORAGE RACK

IMPORTANT: READ ALL INSTRUCTIONS CAREFULLY BEFORE INSTALLING THIS PRODUCT. PLEASE KEEP INSTRUCTIONS FOR FUTURE REFERENCE.

The Les Mills VERTICAL STORAGE rack has been specifically designed for storing Les Mills equipment. Subject to the weight restrictions outlined below, it can store up to twelve Weight Plates (maximum of four Weight Plates on each weight hanger) and two SMARTBAR™, or one SMARTBAR and multiple SMARTBAND™. Each side hook can hold a maximum of one SMARTBAR or multiple SMARTBANDs as depicted in the drawing below.

When storing Weight Plates, the heaviest Weight Plates should always be located on the lowest Weight hanger, at the bottom of the VERTICAL STORAGE rack.

The maximum capacity per Weight Hanger set is outlined in the below illustration.

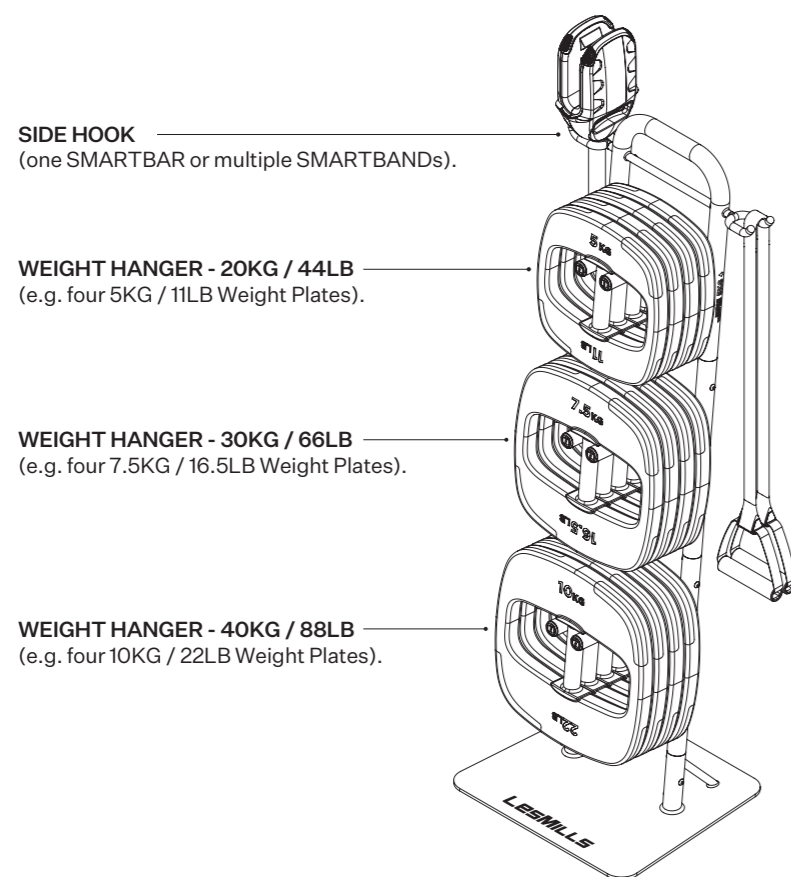

SAFETY INFORMATION



WARNING: FAILURE TO ADHERE TO THESE INSTRUCTIONS COULD RESULT IN SERIOUS INJURY OR DEATH.



CHOKING HAZARD: SMALL PARTS IN THE INSTALLATION KIT COULD PRESENT A CHOKING HAZARD.



WARNING: FAILURE TO INSTALL THE ANTI-TIP STRAP COULD RESULT IN SERIOUS INJURY OR DEATH.

- **ALWAYS** ensure the supplied Anti-tip kit is installed to prevent injury.
- Place the VERTICAL STORAGE rack against a wall, in a clearly accessible area on a hard flat surface. This area should be free from other obstructions such as slanted ceilings, and within easy reach of the user.
- This VERTICAL STORAGE rack is not a toy and should only be used by those aged 14 years or older.
- The owner of this VERTICAL STORAGE rack is responsible for ensuring that all users of this product are adequately informed of all the safety information.
- Only use this VERTICAL STORAGE rack as a storage facility for specified Les Mills equipment.
- Do not place any additional load on the VERTICAL STORAGE rack other than what it has been designed to accommodate. Overloading may impair stability and lead to equipment falling off, potentially causing serious injury or even death.
- This VERTICAL STORAGE rack is only intended for personal domestic use. Do not use this product in any commercial or institutional setting.
- Keep children away to prevent injury from climbing or hanging on the VERTICAL STORAGE rack. Never leave children unsupervised with the VERTICAL STORAGE rack. Children could get seriously injured by falling equipment or by fall off the VERTICAL STORAGE rack themselves.
- Keep the VERTICAL STORAGE rack indoors and away from any moisture and dust.
- After assembling the VERTICAL STORAGE rack, and before each use, carefully inspect the rack to ensure there is no damage and the screws are tight.
- The VERTICAL STORAGE rack must not be modified.

CARE & MAINTENANCE

- After assembling the VERTICAL STORAGE rack, and before each use, carefully inspect to ensure there is no damage and the screws are tight. Stop use of the VERTICAL STORAGE rack immediately if there are any signs of damage.
- For cleaning, please wipe the VERTICAL STORAGE rack with a clean, damp cloth with mild detergent. Please then dry with a clean, dry cloth.
- Keep the VERTICAL STORAGE rack indoors and away from any moisture and dust.
- Do not attempt to repair the VERTICAL STORAGE rack yourself.
- If you have any difficulties with the assembly or the use of this VERTICAL STORAGE rack, or if you think that any parts are missing, please get in touch with your local Les Mills authorised equipment distributor.
- If you no longer want your VERTICAL STORAGE rack, please dispose responsibly, in accordance with local household recycling guidelines.

PARTS INCLUDED

The Les Mills VERTICAL STORAGE rack comprises of the following components:

- | | |
|---------------------|-----------------------------|
| ① 1x Base plate | ⑧ 19x M6 x 10mm screws |
| ② 1x Lower frame | ⑨ 6x M6 x 40mm screws |
| ③ 1x Middle frame | ⑩ 2x M4 x 8mm screws |
| ④ 1x Upper frame | ⑪ 3x 30mm long screws |
| ⑤ 3x Weight hangers | ⑫ 3x Wall expansion anchors |
| ⑥ 2x Side hooks | ⑬ 1x M6 Allen key |
| ⑦ 1x Anti-tip strap | ⑭ 1x M4 Allen key |

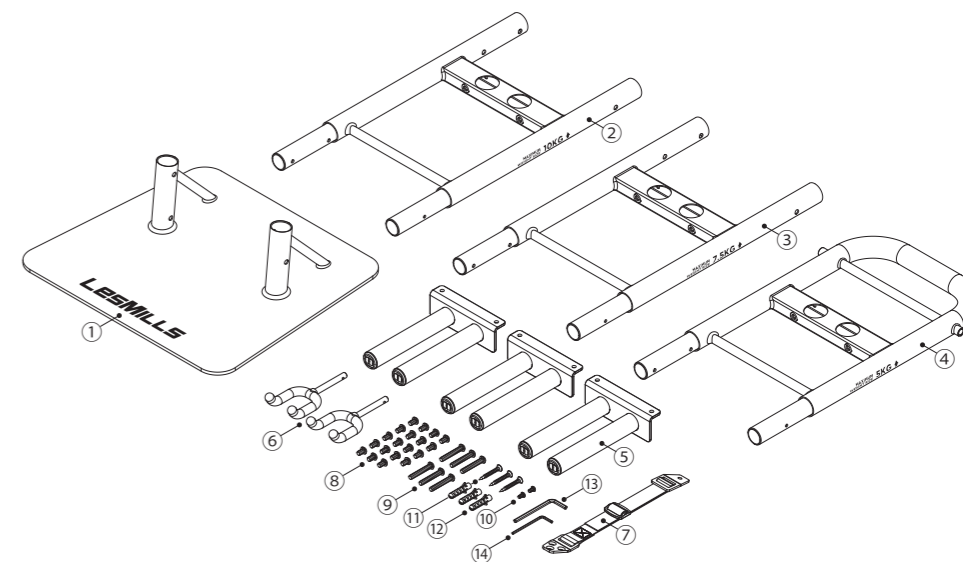

You will also need the following tools:

- | | |
|---|--|
| ⑭ Pencil | ⑰ Stud Finder |
| ⑮ Philips Screwdriver | ⑱ Power Drill |
| ⑯ Ø 7/64" (3mm) wood drill
(for plasterboard/wood walls) | ⑲ Ø 7/32" (5.5mm) concrete/brick drill
(for concrete/brick walls) |

ASSEMBLY AND INSTALLATION INSTRUCTIONS

Prior to assembly, remove all components from the packaging and check against the parts list on the previous page. If any parts are missing or you notice any sign of damage please return the VERTICAL STORAGE rack to your local equipment distributor. Please ensure that no equipment is placed on the VERTICAL STORAGE rack during assembly.